

## End View

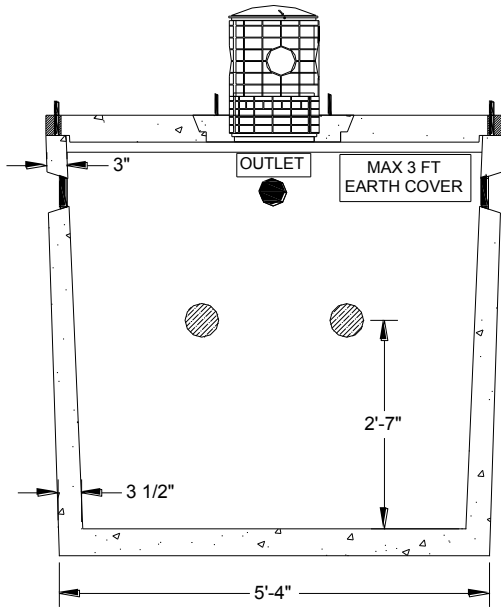

## Cross Section

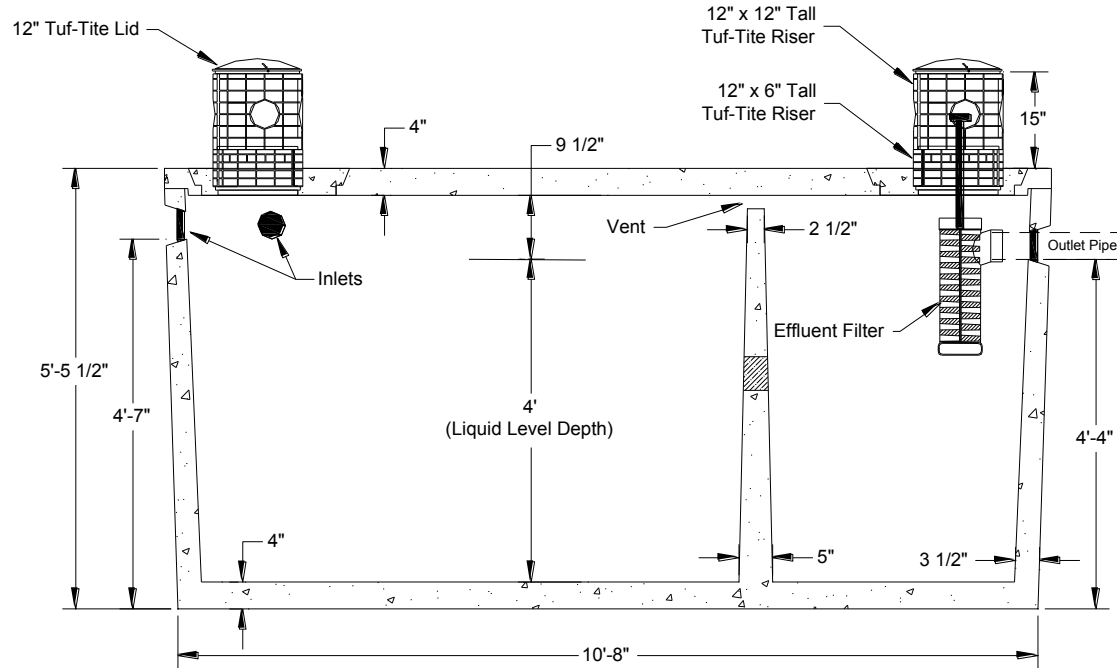

## SPECIFICATIONS

**Tank:** Manufactured per 2013 Montana Circular DEQ-4 Chapter 5 design standards for septic tanks, Tuf-Tite TS-4Pro pipe seals cast in for inlet and outlet pipe penetrations, 2 EA 12" dia. x 6" tall Tuf-Tite risers cast into 20" cleanout lids.

**Standard Components:** 2 EA 12" dia. x 12" tall Tuf-Tite riser extensions, 2 EA 12" Tuf-Tite lids, SS screws, Tuf-Tite EF-6 Combo (1500 GPD) effluent filter with 1/2" dia. PVC handle extension, ConSeal CS-102 1" butyl rubber sealant to seal tank lid.

**NOTE 1):** Tank must be installed per Billings Precast's 'Tank Installation Guide' or warranty will be VOID.

**NOTE 2):** Tank shall not be placed in a traffic area (ie. parking lot, driveway, etc.) - Warranty will be VOID if driven on.

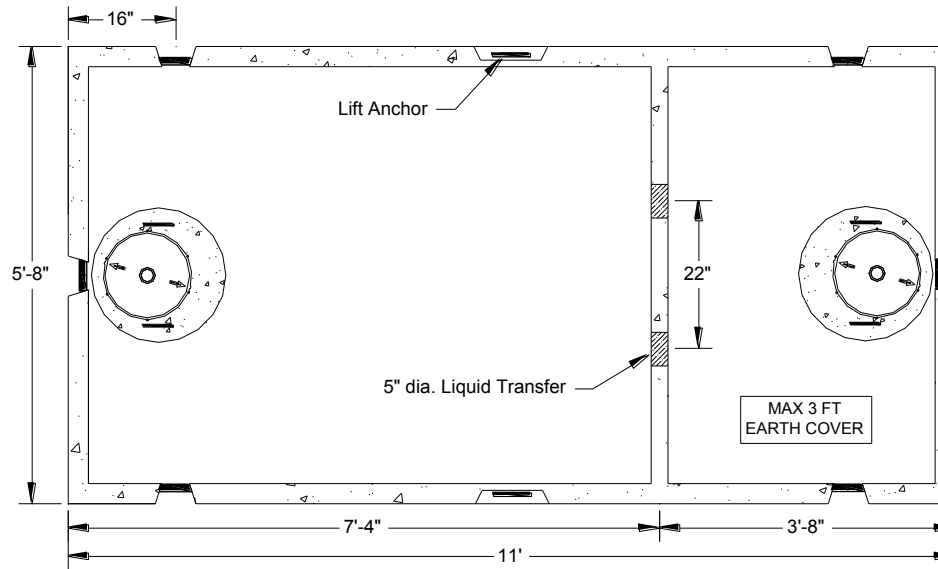

## Top View

**WEIGHTS:** Tank - 10,300 lb.; Lid - 3000 lb. [ Total Assembled = 13,300 lb. ]

5815 Interstate Avenue  
Billings, Montana 59101  
PHONE (406) 656-6098  
FAX LINE (406) 656-4942  
billingsprecast.com



# ST15SD

1500 Gallon Single Piece Septic Tank  
- Two Compartment -

DWG. NO.

SCALE: NONE

DATE: 2-4-14

REV: A  
DRN: WDB