

## End View

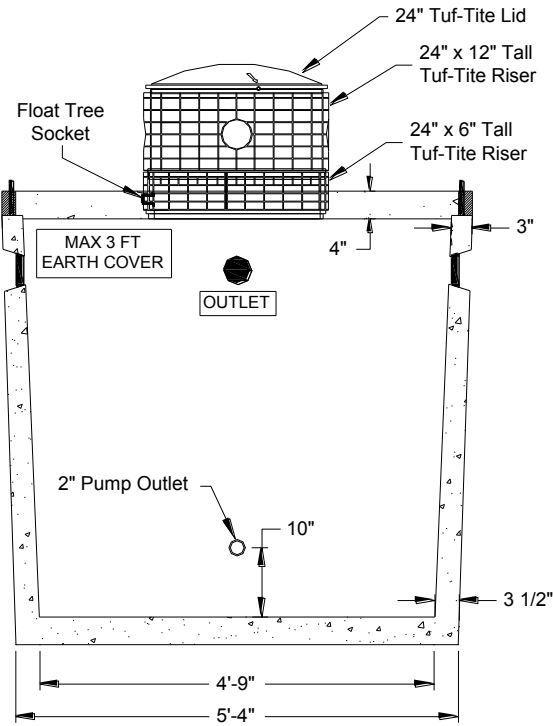

## Cross Section

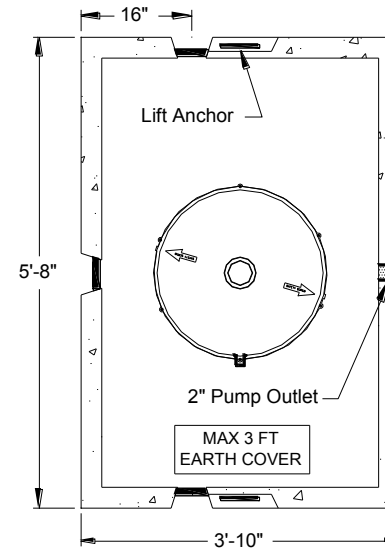
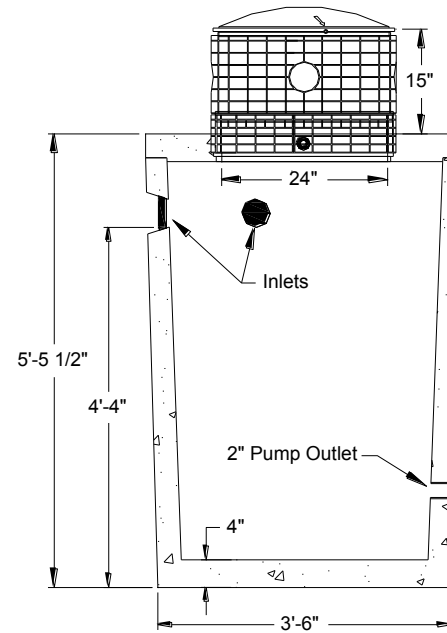

## Top View

### SPECIFICATIONS

**Tank:** Manufactured per 2013 Montana Circular DEQ-4 Chapter 5 design standards for septic tanks, Tuf-Tite TS-4Pro pipe seals cast in for inlet and outlet pipe penetrations, 1" PVC float tree socket, 1 EA 24" dia. x 6" tall Tuf-Tite access riser cast into tank lid, 1 EA 2" Sch40 PVC coupler cast in tank wall for pump outlet.

**Standard Components:** 1 EA 24" dia. x 12" tall Tuf-Tite access riser extension, 1 EA 24" Tuf-Tite lid, SS screws, ConSeal CS-102 1" butyl rubber sealant to seal tank lid.

**NOTE 1):** Tank must be installed per Billings Precast's 'Tank Installation Guide' or warranty will be VOID.

**NOTE 2):** Tank shall not be placed in a traffic area (ie. parking lot, driveway, etc.) - Warranty will be VOID if driven on.

WEIGHTS: 5000 lb.

5815 Interstate Avenue  
Billings, Montana 59101  
PHONE (406) 656-6098  
FAX LINE (406) 656-4942  
billingsprecast.com



**DT05S**

500 Gallon Dosing Tank  
- Single Piece Tank -

DWG. NO.

SCALE: NONE

DATE: 2-5-14

REV: A  
DRN: WDB